

ES-1000II
ES-1000sII



操作简单 | Easy operation

采用7.5英寸彩色液晶触摸屏,画面大,易操作。
Operation is easy on the big screen.

操作面板按键根据不同功能进行配色,增强了识别度。
The color scheme of the operation sheet key was distinguished for every function, and visibility was improved.

装载USB通信端口,与电脑连接便捷。
USB communication port, Allows PC connection.

可3国语言切换(可进行英文、日文、简体中文的切换)
Three languages exchange(English, Japanese and Chinese(new))



250-450t
适用注塑机吨位
injection Press range
250~450ton

节能·削减电力和空气消耗量
Saving Energy · Consumption of power consumption and air is reduced.

LM导轨·走行,上下及前后轴采用THK精密导轨
LM Guide · All axis use THK guide with exquisite precision

最大限度减少震动,具有高刚性和稳定性的特点。
To minimize the vibration and be with high rigidity and stability.

耗电量削减 约25% Power consumption reduced by 25%
空气消耗量削减 约75% Air consumption reduced by 75%

基本参数 | COMMON SPECIFICATIONS

电源 Power Source	常用气压 Air Pressure	驱动方式 Drive System	姿势(气缸) Posture (Air Cylinder)	气缸推力(气压:0.5Mpa时) Air Cylinder Driving Force (Air Pressure at 0.5Mpa)		控制箱 Control Box
				最大可搬重量 Max. Load	姿势力矩 Posture Torque	
AC200V ±10% 50/60Hz(单相) Single Phase	0.5Mpa	AC伺服马达 AC Servo Motor	90° 固定 90° Fixed	5kg (含夹具重量) Incl Chuck Weight	20.2N·m	STEC-NC2a

综合参数 | GENERAL SPECIFICATIONS

机种 Model	行程(移动量)(mm) Stroke				电源设备容量 (KVA) Electric Consumpton	最大消费电力 (KW) Max Power Consumpton	机器重量(kg) Net Weight		空气消耗量 (Nℓ/周期) Air Consumption (Nℓ/Cycle)
	上下 Ⓟ Vertical	上下 Ⓠ Vertical	前后 Crosswise	走行 Traverse			本体 Main Body	操作盒 Pendant	
ES-1000II	1000	—	97~933	1800 [1600]	1.4	1.1	259.2	1.1	1.40
ES-1000sII		1050	Ⓟ 263~933 Ⓠ 115~785		2.6	1.7	282.3		

Ⓟ []尺寸表示选项行程。

Ⓠ 本体重量包括控制箱及电缆线的重量。

Ⓟ: 表示制品侧手臂, Ⓠ: 表示水口侧手臂。

Ⓠ 将走行行程为1800mm行程的走行体向取出侧移动200mm时,走行行程将变为1600mm。

Ⓠ Figure in [] shows option stroke.

Ⓠ Net weight includes the weight of interlock box and driver box.

Ⓠ In the column of stroke, Ⓟ stands for product side arm and Ⓠ stands for runner side arm.

Ⓠ Make the traverser as 1800 mm moving forward to extracting side as 200 mm it will be 1600 mm.

标准功能 | STANDARD FUNCTIONS

取出下降待机 Delayed arm descent	节能吸着确认单元(1回路) Energy saving vacuum confirmation unit (1circuit)	顶针联动 Ejector link	水口模内开放 Runner release within mold
前进取出侧姿势控制 Crosswise product extract side posture control	滑移取出自由 Free extract for under-cut mold	顶针后退联动 Ejector return link	固定可动切换 Extraction from fixed mold
前后自由伺服点 Crosswise Free Servo point	走行途中姿势 Posture control during traverse	水口途中落下(走行·复归) Midway runner release (Move·Revert)	不良品排出 Defective product reject
初期不良品排出 Initial defective product reject	横走行待机 Delayed traverse	落下侧下降途中姿势 Posture midway descent at release side	装箱点 Point packaging
自由装箱点(100点×2级) Point free packaging (100 points × 2 stage)	输送带启动信号 Start signal of conveyor	3国语言切换(简体中文、日文、英文) Three language exchange (Chinese(new), Japanese, English)	插入式用户编程 Easy NC steps (USER PROGRAM EDITING)
外部存储记忆 External storage memory	设定值隐藏功能 Default blind feature	伺服休眠 Servo sleep feature	背景灯自动OFF Backlight Auto OFF
USB通信端口 USB communication port			

选项功能 | OPTION FUNCTIONS

节能吸着确认单元(2回路) Energy saving vacuum confirmation unit (2circuits)	节能吸着确认单元(4回路) Energy saving vacuum confirmation unit (4circuits)	夹具减压阀 Chuck pressure regulator	旋转功能 Rotation Unit
上升途中闭模 Mold close during arm ascent	制品确认 (LS-4) Product confirmation LS-4	剪切回路(夹具内) Air nipper in chuck circuit	制品2点开放 Release product at two different points
制品4点开放 Release product at four different points	NT剪切·可动侧(有单元) NT gate cutting on crossmember of moving mold side (w/unit)	警报灯(红色·无蜂鸣器) Alarm Lamp (Red color, w/o buzzer)	自动快速交换用夹具(气压式) Quick chuck change automatic (air sw)
操作盒支架 Pendant stand	姿势·旋转 2NC Servo posture & rotate	CNC编程功能 CNC program editing function	欧规 12 EUROMAP 12 Specification
			欧规 67 EUROMAP 67 Specification

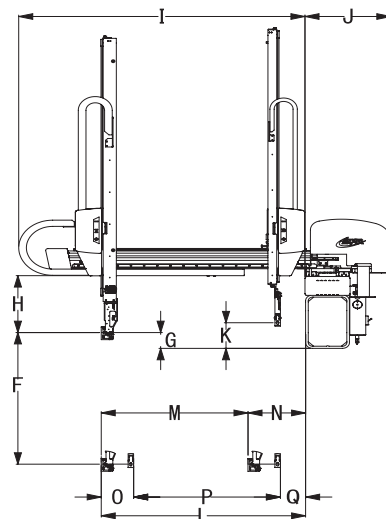
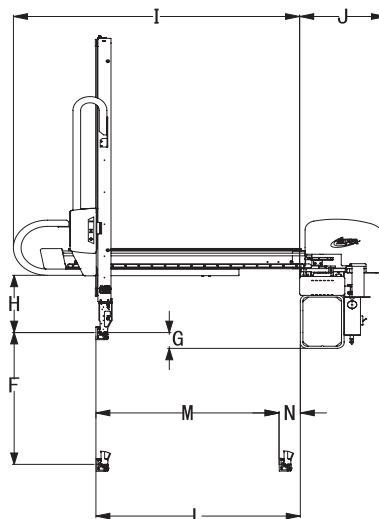
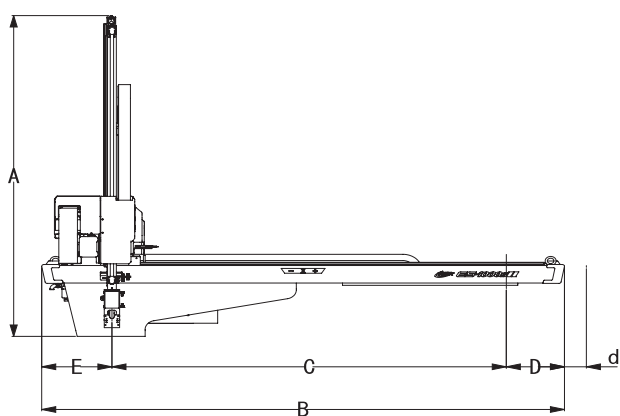

外形尺寸(mm) | OUTER DIMENSIONS

		ES-1000II	ES-1000sII	
A	全高 / Overall height	1760	1810	
B	全幅 / Overall width	2400[2400 ²]		◎[]内的尺寸表示选项行程。
C	走行行程 / Traverse stroke	1800[1600 ²]		◎水口夹的厚度为25mm。
D	落下侧突出位置 / Overhang, release side	270[270 ²]		◎姿势部厚度为69mm。但根据配管方式不同, 此尺寸多少会有些不同。
E	取出侧突出位置 / Cable guide overhang	330[530 ²]		◎水口侧上下行程比制品侧上下行程长50mm。
F	◎制品侧上下行程 / ◎Vertical stroke	1000		◎*1表示F尺寸为1000mm。
G	◎制品侧上下待机位置 / ◎Vertical standby	90		◎*2表示C尺寸为1600mm。
H	夹具安装位置上方有效尺寸 / Bottom of crosswise to chuck mount position	320		◎Figure in [] shows option stroke.
I	前后单元 / Crosswise arm	1340		◎Thickness of runner chuck is basically about 25 mm.
J	本体厚度 / Thickness	391		◎Thickness of posture area is basically about 69 mm (depends on tubing)
K	◎水口侧上下待机位置 ◎Vertical standby	—	140	◎Runner side vertical stroke is 50 mm longer than that of product side.
L	◎制品前进MAX ◎Crosswise reach max	933		◎*1 When dimension F is 1000 mm.
M	◎制品前进行程MAX ◎Crosswise stroke max	836	670	◎*2 When dimension C is 1600 mm.
N	◎制品前后待机MIN ◎Crosswise standby min	97	263	
O	◎接近MIN ◎Proximity min	—	148	
P	◎水口侧前后行程MAX ◎Crosswise stroke max	—	670	
Q	◎水口侧前后待机MIN ◎Crosswise standby min	—	115	

●因改良等原因, 规格及外观有所变更时, 不再另行通知, 敬请包涵。All stated here is subject to change without advance notice.

for more information
www.starseiki.cn

星精机械(上海)有限公司 上海市徐汇区桂平路555号46栋208室
TEL: 021-5423 4571 FAX: 021-5423 4570

STAR 机械手销售网点 - 中国地区

星精机械(上海)有限公司 深圳分公司 广东省深圳市宝安区沙井镇博岗松山工业区松山西路6号 TEL:+86-755-29622620 FAX:+86-755-29622341	星精机械(上海)有限公司 余姚事务所 浙江省宁波余姚市凤山街道舜汇东路78号415室 TEL:+86-574-62532721	星精机械(上海)有限公司 苏州分公司 江苏省苏州市高新区金山路198号安达科技园6栋4楼6009室 TEL:+86-512-68058385 FAX:+86-512-68058250
星精机械(上海)有限公司 广州分公司 广东省广州番禺区南村镇兴业大道3号畅兴大厦四楼A007室 TEL:+86-20-37084205 FAX:+86-20-37084277	星精机械(上海)有限公司 成都分公司 成都市郫都区丛东路109号万达广场13栋1单元2601 TEL:+86-28-6549 5545	星精机械(上海)有限公司 大连分公司 大连市经济技术开发区亿锋现代城3栋15-12室 TEL:+86-411-87562176 FAX:+86-411-87562937
星精机械(上海)有限公司 武汉事务所 湖北省武汉市经济技术开发区东风大道111号经开万达广场B3栋14-16号 TEL:+86-27-84253500 FAX:+86-27-84792646	星精机械(上海)有限公司 重庆事务所 重庆市渝北区金渝大道68号新科国际广场3栋17-18 TEL:+86-23-60360877 FAX:+86-23-60360968	星精机械(上海)有限公司 天津分公司 天津市南开区复康路海泰信息广场B-806室 TEL:+86-22-58387675 FAX:+86-22-58112975
星精机械(上海)有限公司 厦门事务所 福建省厦门市湖里区长乐路3号海发商务大厦二期A308室 TEL:+86-592-5779994 FAX:+86-592-5779994	星精机械(上海)有限公司 青岛分公司 山东省青岛市城阳区春阳路167号办公室411室 TEL:+86-532-55565517 FAX:+86-532-55565518	中日龙(襄阳)机电技术开发有限公司(生产工厂) 湖北省襄阳市高新技术产业开发区汉江北路79号 TEL:+86-710-3311 813 FAX:+86-710-3320 152